

5000 Series Lead Free ($\leq .25\%$ Lead) Mixing Valve

This versatile NSF 61 ASSE 1017 mixing valve provides the ultimate performance for domestic hot water installations. The 5000 Series allows for domestic hot water storage at temperatures high enough to increase the effective storage capacity of a water heater, kill harmful bacteria and still be delivered at a safe 120°F or less.

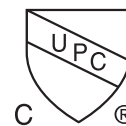

NSF[®] $\leq .25\%$ Lead

Meets California AB 1953
and Vermont Act 193



Submittal Data Information

5000 Series Lead Free Mixing Valve

NSF₆₁ ≤ .25% Lead

Meets California AB 1953 and Vermont Act 193

Submittal Data # 101-060
Supersedes: 03/01/06

Effective: 07/31/13

Features

- ≤ .25% lead
- ASSE 1017 Listed
- Ideal for Domestic Water Distribution Points
- Suitable for use in Potable Water
- Delivers Stable Mixed Water Temperature
- Extended Mix Temperature Range of 85-176°F (29-80°C)
- Tamper-Resistance Cap
- Union and NPT Options
- Sweat, NPT, Pex, CPVC Union Connections
- Low Headloss
- Outlet Temperature Strip
- Optional Dial Gauge and Adaptor

Performance

- CV: 2.3
- Max. Flow: 20 gpm (76 L/Min)
- NOTE: Flow should never exceed standards for pipe size.
- Min. Flow: 1 gpm (3.8 L/Min)
- Hot Supply Temperature: 120-180°F (49-82°C)
- Cold Supply Temperature: 39-80°F (5-27°C)
- Max. Inlet Pressure: 230 psi (15.85 Bar)
- Max. Variation in Supply Pressure: 20%
- Min. Temperature Differential Between Hot Supply and Mixed: 27°F (15°C)
- Outlet Temperature Range: 85-175 F (29-80°C)
- Factory set to: 115-120°F (41-45°C)

- Accuracy of Outlet Temperature: ± 3°F

Materials

- Body: Forged Brass ≤ .25% lead Brass
- Internal Components:
 - ≤ .25% lead Brass
 - Noryl GFN2
- Seals: Viton
- Spring: Stainless Steel
- Piston: Polysulfone
- Fittings: Varies (Brass, CPVC, Copper)
- Gaskets: EPDM

Approvals

- ASSE 1017
- cUPC Listed
- CSAB125.3



Application

This versatile NSF 61 and ASSE 1017 mixing valve provides the ultimate performance for domestic hot water applications. The 5000 Series ASSE 1017 certification allows for domestic hot water storage at temperatures high enough to increase the effective storage capacity of a water heater, kill harmful bacteria and still be delivered at a safe 120°F or less. The valves unique design and advanced thermostatic element ensures a stable mixed water temperature throughout the extended 85°-176°F range.

Low Temperature or Radiant Installation

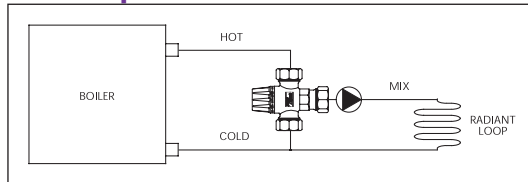

Typical Domestic Water Installation

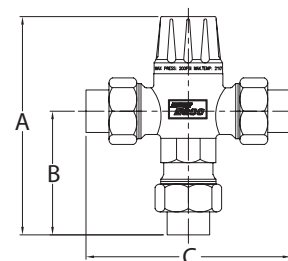
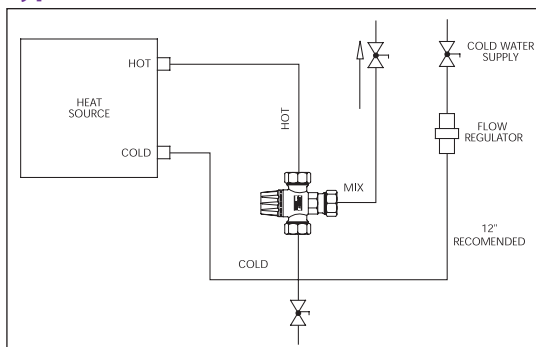

5000 Series Mixing Valve Dimensions

| Taco Model | Description | A Height | | B Lower Height | | C Width | |
|------------|------------------|----------|-------|----------------|-------|---------|--------|
| | | In. | mm | In. | mm | In. | mm |
| 5002-B3 | 1/2" UNION CPVC | 5.8 | 147.3 | 3.7 | 94 | 7.1 | 180.3 |
| 5002-C3 | 1/2" UNION SWEAT | 4.8 | 121.9 | 2.7 | 68.6 | 4.8 | 121.9 |
| 5002-P3 | 1/2" UNION PEX | 5.06 | 128.5 | 2.9 | 73.7 | 5.4 | 137.2 |
| 5002-T3 | 1/2" UNION NPT | 5.3 | 134.6 | 3.2 | 81.3 | 5.8 | 147.3 |
| 5003-B3 | 3/4" UNION CPVC | 5.8 | 147.3 | 3.7 | 94 | 7.1 | 180.3 |
| 5003-C3 | 3/4" UNION SWEAT | 5 | 127 | 2.9 | 73.7 | 5.4 | 137.2 |
| 5003-N3 | 3/4" NPT FEMALE | 4.3 | 109.2 | 2.2 | 55.9 | 3 | 76.2 |
| 5003-P3 | 3/4" UNION PEX | 5.1 | 129.5 | 2.9 | 73.7 | 5.4 | 137.2 |
| 5003-T3 | 3/4" UNION NPT | 5.5 | 139.7 | 3.4 | 86.4 | 6.3 | 160.02 |
| 5004-C3 | 1" UNION SWEAT | 6.1 | 154.9 | 4 | 101.6 | 5.4 | 137.2 |
| 5004-P3 | 1" UNION PEX | 5.2 | 132.1 | 3.1 | 78.7 | 5.8 | 147.3 |

Dimensions for reference only



Taco Inc., 1160 Cranston Street. Cranston, RI 02920 / (401) 942-8000 / Fax (401) 942-2360
Taco (Canada) Ltd., 8450 Lawson Road, Unit #3, Milton, Ontario L9T 0J8 / (905) 564-9422 / Fax (905) 564-9436

www.taco-hvac.com