

Series 5000

**ARMSTRONG**



## Sump and Sewage Systems

FILE NO:	50.10
DATE:	MAY 17, 2013
SUPERSEDES:	50.10
DATE:	MARCH 29, 2013

## Sump Series 5200 & 5240

Armstrong offers a complete range of high performance, easily maintained Column Type Sump & Sewage Pumps. Built from the highest quality engineered components, these pumps can be supplied as replacement pumps or as part of a new installation. Armstrong systems are available with control panel, level controls, and sump pit cover plate.

### Sewage Series 5200 & 5240

Armstrong sump pumps are offered in two designs, engineered to handle a wide range of waste water pumping requirements.

#### 5200 Standard Features

- 304 centerless ground stainless steel shaft
- Enclosed-type bronze impeller, keyed to shaft
- Cast iron inlet strainer
- Flexible coupling
- Plate-mounted alemite grease fittings
- Intermediate grease-lubricated bronze guide bearings for pit depths over 4 ft. (1.2m)

#### 5240 Standard Features

- 1¼" (32mm) heavy-duty carbon steel shaft
- Heavy-duty grease-lubricated bronze guide bearings
- Enclosed-type bronze impeller
- Cast iron inlet strainer
- Flexible coupling
- Raised thrust bearing mounted in a dirt and moisture resistant housing
- Plate-mounted alemite grease fittings
- Intermediate grease-lubricated bronze guide bearings for pit depths over 5 ft. (1.5m)
- Flanged pump column pipe

#### 5240 Optional Features

- Pump conversion for condensate service consisting of water lubricated graphite pump bearings, stainless steel shaft and bronze impeller
- Water lubricated cutless rubber bearings
- 304 stainless steel shaft

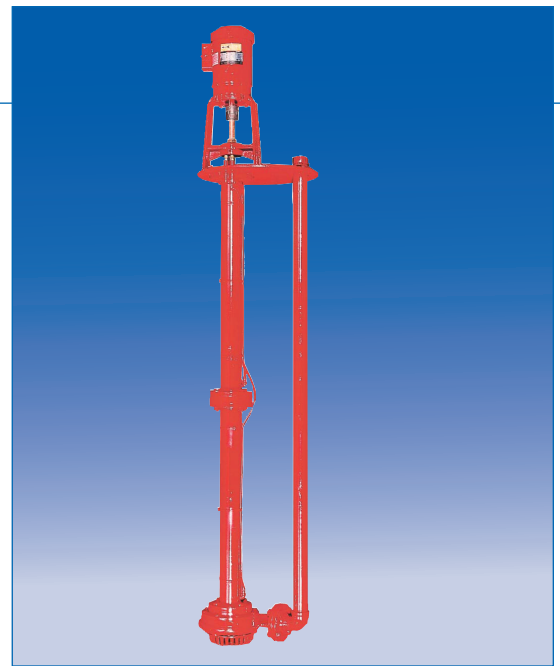

Armstrong sump pump designs address the specific requirements for light-duty or heavy-duty commercial applications such as: elevator pits, electrical tunnels, loading docks, drain tiles, laundry facilities, floor drains and condensate returns.

# Sewage Series 5400

Armstrong 5400 Series sewage pumping systems for building, municipal and industrial applications provide a top-quality, reliable and long-lasting product.

## Sewage Series 5400 Pumps

Armstrong sewage pumps feature a screenless design, capable of handling waste material and sewage up to 2½" (64mm) solids.

### Standard Features

- 1¼" (32mm) carbon steel shaft
- Gas-tight construction
- Raised thrust bearing mounted in a dirt and moisture resistant housing
- Cast iron 2-vane open-type impeller
- Floor plate mounted alemite grease fittings
- Grease-lubricated bronze guide bearings for pit depths over 5 ft. (1.5m)
- Flanged pump and column pipe

### Optional Features

- Water-lubricated cutless rubber bearings
- Water-lubricated graphite bearings
- 304 stainless steel shaft

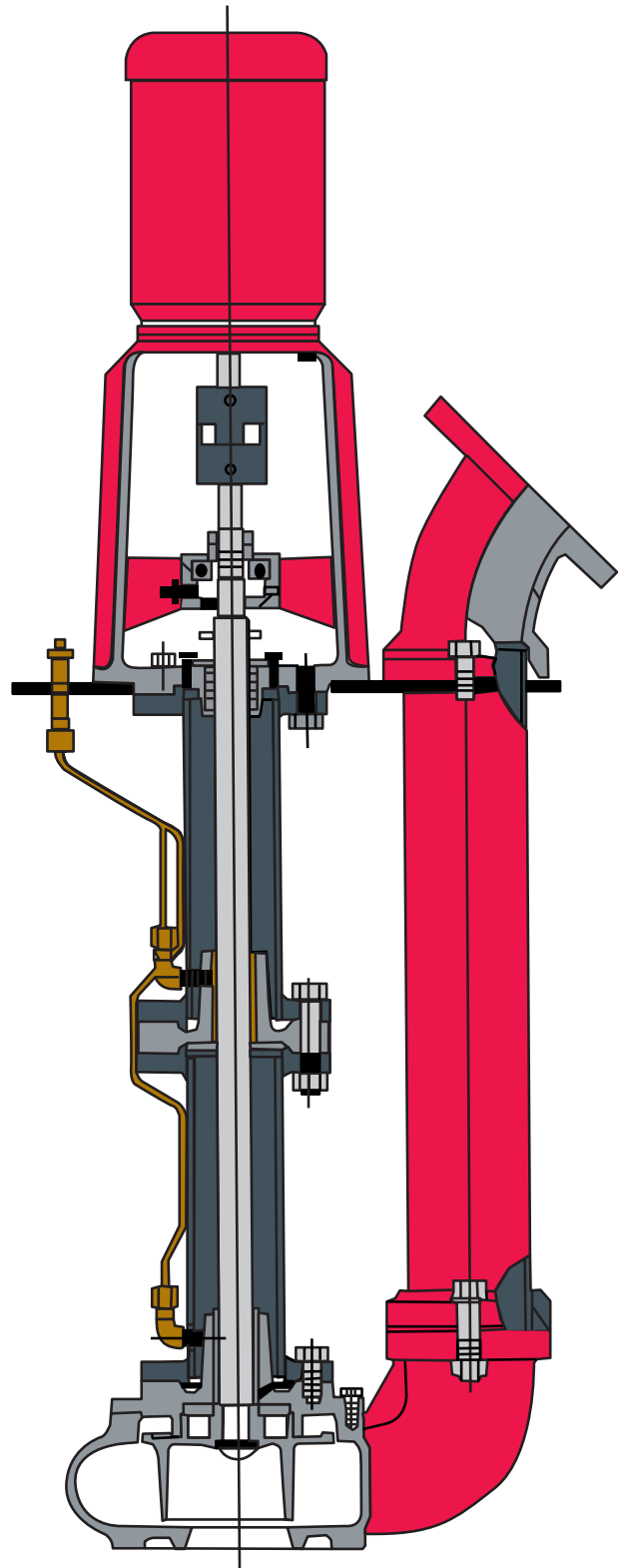

## Controls & Accessories

Choose Armstrong pumping systems for reliability, efficiency and quality engineered products.

### Control Panel

Armstrong Sump & Sewage systems are available with a variety of starting equipment choices.

### Features

- NEMA 1 control panel enclosure
- UL 508 or CSA approved
- Main disconnect
- Thermal and short circuit protection using internal circuit breakers
- Failure protection with automatic transfer to non-operating pump (duplex system)
- Control transformer with fused primary (UL 508)
- Power-on and pump-run indicating lights
- Hand-Off-Automatic selector switch

### Optional Features

- NEMA 2, 3, 4, 4X or 7 enclosure
- High level buzzer or 4" (101mm) bell, indicating light and silence reset push button
- Overload pilot lights
- Elapsed time meters
- Individual disconnect switches
- Electrical alternation (duplex system)

### Cover Plate and Curb Frame

Circular or square sump cover plate and curb frame can be supplied with openings for simplex or duplex pump configurations. Cover plate includes 3" (76mm) NPT threaded vent and inspection cover.

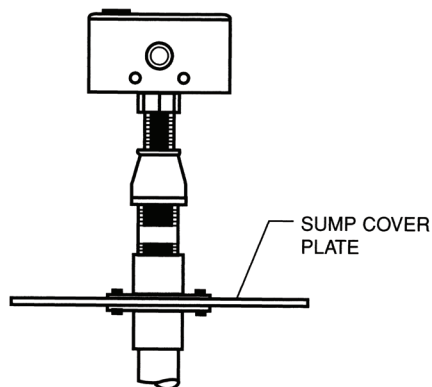

COMPRESSION HIGH WATER SWITCH

- Senses static head pressure between media and bellows in the switch enclosure
- As liquid level rises, trapped air in compression pipe causes bellows to expand and trips the microswitch activating an external circuit as well as an integral alarm

### Level Controls

Ball and rod type float switch governs the control of pump operation based on sump liquid level. Level controls are mounted on a cast iron pedestal and bolted to sump cover plate.

### Features

- Copper ball, brass float rod and stops, float guide pipe and cast iron pedestal
- Mechanical alternator with emergency start position is supplied with duplex units

### Optional Features

- High level alarm devices are mounted on sump cover plate and can be provided in two types:
  - a) NEMA 1 compression type switch with integral buzzer and alarm contract
  - b) Ball & rod float switch, to be wired to separate alarm panel or alarm bell
- NEMA 4 or NEMA 7 enclosure
- Bulb-type level controls supplied with mounting plate, electrical connectors, and level control support

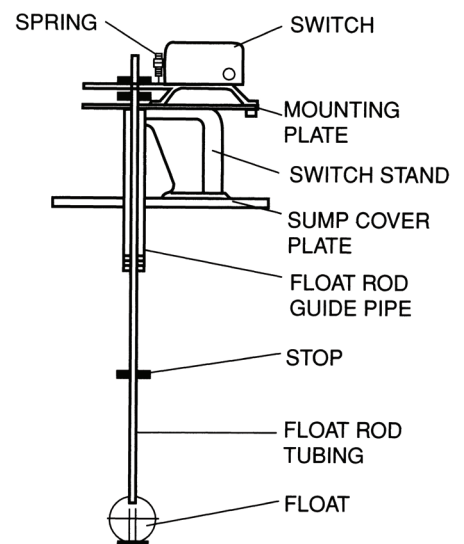

FLOAT SWITCH

# Composite Charts

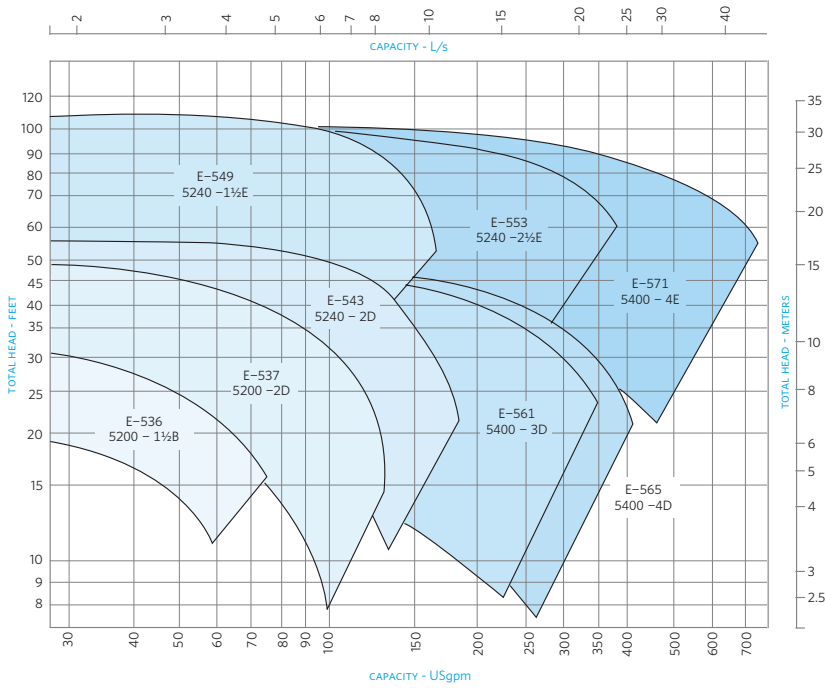

## 1750 rpm

CURVE NO.	PUMP	SIZE	MAX. SOLID SIZE
E-536	5200	1½ <sub>28</sub>	Bilge Water only
E-537	5200	2D	Bilge Water only
E-543	5240	2D	Bilge Water only
E-549	5240	1½E	Bilge Water only
E-553	5240	2½E	Bilge Water only
E-561	5400	3D	2" (50mm) dia.
E-565	5400	4D	2 <sup>11</sup> / <sub>42</sub> " (64mm) dia.
E-571	5400	4E	2 <sup>11</sup> / <sub>42</sub> " (64mm) dia.

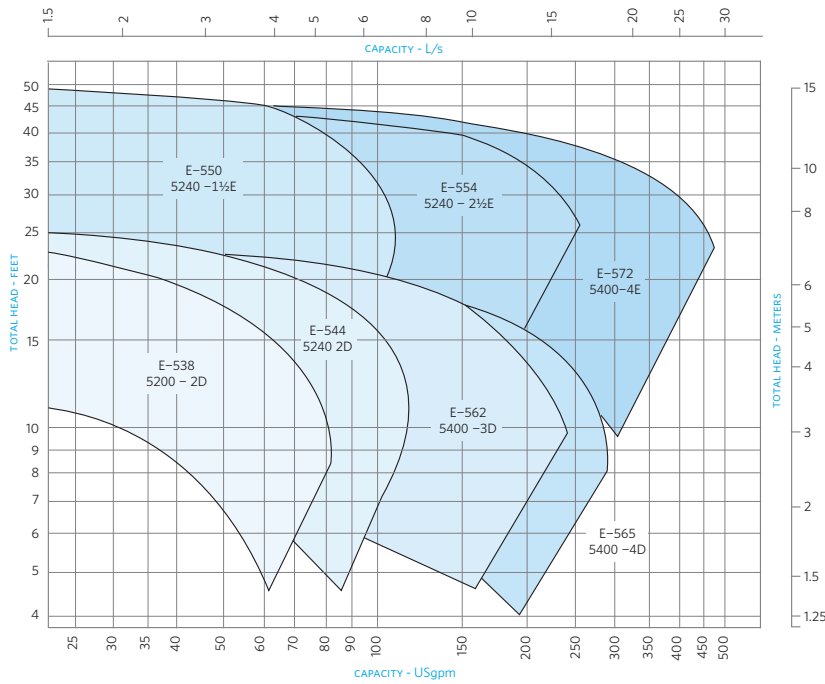

## 1150 rpm

CURVE NO.	PUMP	SIZE	MAX. SOLID SIZE
E-538	5200	2D	Bilge Water only
E-544	5240	2D	Bilge Water only
E-550	5240	1½E	Bilge Water only
E-554	5240	2½E	Bilge Water only
E-562	5400	3D	2" (50mm) dia.
E-566	5400	4D	2 <sup>11</sup> / <sub>42</sub> " (64mm) dia.
E-572	5400	4E	2 <sup>11</sup> / <sub>42</sub> " (64mm) dia.

## Section &amp; Parts List

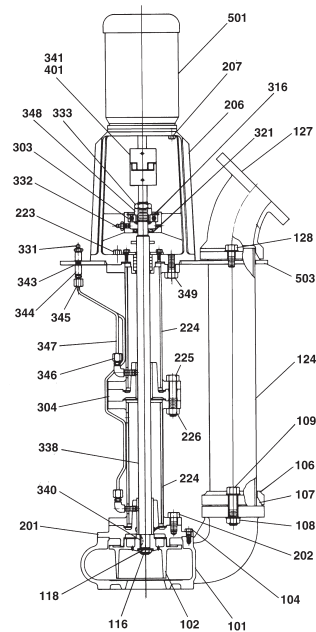
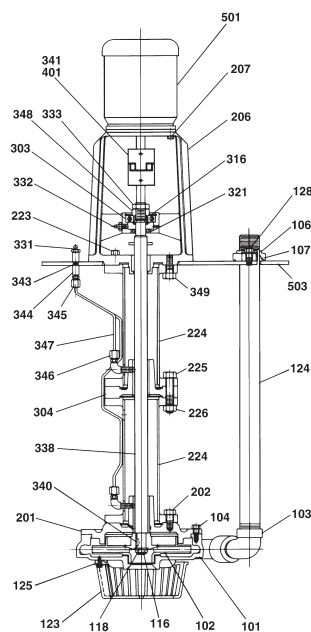
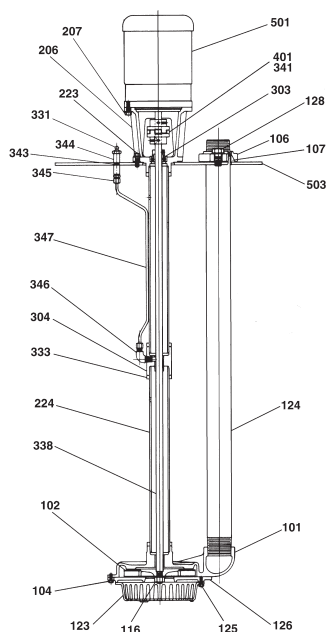

## Series 5200 Sump Pump

## Series 5240 Sump Pump

## Series 5400 Sewage Pump

ITEM NO.	DESCRIPTION	ITEM NO.	DESCRIPTION	ITEM NO.	DESCRIPTION
101	Volute	128	Discharge Pipe Screw & Washer	332	Grease Fitting
102	Impeller	201	Cover Plate & Lower Bearing	333	Lock Nut
103	Lower Discharge Elbow	202	Cover Plate Screw	338	Shaft
104	Volute Screw	206	Motor Support	340	Impeller Key
106	Discharge Flange	207	Motor Screw	341	Coupling Key
107	Discharge Flange Gasket	223	Support Screw	343	Pipe Nipple
108	Flange Nut	224	Column Pipe	344	Pipe Coupling
109	Flange Bolt	225	Intermediate Bearing Screw	345	Tube Connector
116	Impeller Nut	226	Intermediate Bearing Nut	346	Elbow
118	Impeller Washer	303	Ball Bearing	347	Lubrication Tube
123	Strainer	304	Intermediate Bearing Assembly	348	Bearing Collar
124	Discharge Pipe	316	Snap Ring	349	Bearing Frame Screw
125	Strainer Screw	321	Oil Seal	401	Coupling
126	Suction Plate	331	Grease Fitting	501	Motor
127	Discharge Elbow			503	Floor Plate

# Dimensional Data

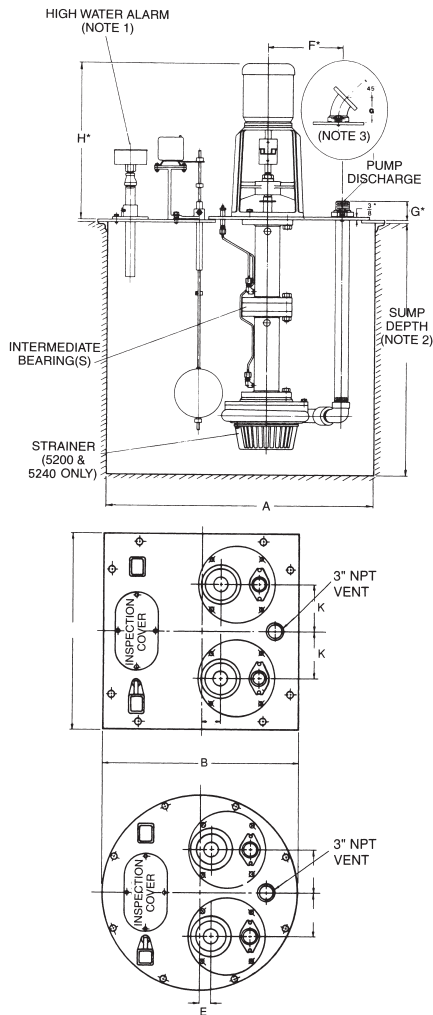
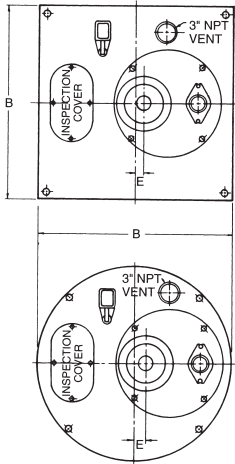

Pump floor plates are 19-7/8" (504 mm) in diameter with four-7/16" (11 mm) holes on a 19" (483 mm) bolt circle.

## COVER PLATES - SIMPLEX UNITS INCHES (mm)

	A SUMP SIZE	B	E							
			5200		5240			5200		
			1½B	2D	2D	1½E	2½E	3D	4D	4E
ROUND	24 (610)	28 (711)	3 (76)	3 (76)	1¼ (32)	1¼ (32)	1¼ (44)	1 (25)	¼ (6)	¼ (6)
	30 (762)	34 (864)	6 (152)	6 (152)	1¼ (44)	1¼ (44)	1¼ (32)	4 (102)	2¼ (70)	2¼ (70)
	36 (914)	40 (1016)	8 (203)	8 (203)	3¼ (95)	3¼ (95)	3¼ (83)	6 (152)	4¾ (121)	4¾ (121)
	42 (1067)	46 (1168)	11 (279)	11 (279)	6¼ (171)	6¼ (171)	6¼ (159)	9 (229)	7¾ (197)	7¾ (197)
	48 (1219)	54 (1372)	11 (279)	11 (279)	6¼ (171)	6¼ (171)	6¼ (159)	9 (229)	7¾ (197)	7¾ (197)
	54 (1372)	60 (1524)	11 (279)	11 (279)	6¼ (171)	6¼ (171)	6¼ (159)	9 (229)	7¾ (197)	7¾ (197)
	60 (1524)	66 (1676)	11 (279)	11 (279)	6¼ (171)	6¼ (171)	6¼ (159)	9 (229)	7¾ (197)	7¾ (197)
SQUARE	24 (610)	28 (711)	3 (76)	3 (76)	1¼ (32)	1¼ (32)	1¼ (44)	1 (25)	¼ (6)	¼ (6)
	30 (762)	34 (864)	6 (152)	6 (152)	1¼ (44)	1¼ (44)	1¼ (32)	4 (102)	2¼ (70)	2¼ (70)
	36 (914)	40 (1016)	8 (203)	8 (203)	3¼ (95)	3¼ (95)	3¼ (83)	6 (152)	4¾ (121)	4¾ (121)
	42 (1067)	46 (1168)	11 (279)	11 (279)	6¼ (171)	6¼ (171)	6¼ (159)	9 (229)	7¾ (197)	7¾ (197)
	48 (1219)	54 (1372)	11 (279)	11 (279)	6¼ (171)	6¼ (171)	6¼ (159)	9 (229)	7¾ (197)	7¾ (197)
	54 (1372)	60 (1524)	11 (279)	11 (279)	6¼ (171)	6¼ (171)	6¼ (159)	9 (229)	7¾ (197)	7¾ (197)
	60 (1524)	66 (1676)	11 (279)	11 (279)	6¼ (171)	6¼ (171)	6¼ (159)	9 (229)	7¾ (197)	7¾ (197)

## MOTOR FRAME SIZE INCHES (mm)

SERIES	56C	143TC	145TC	182TC	184TC	213TC	215TC	254TC	256TC
5200	16¾ (422)	16½ (419)	17½ (445)	-	-	-	-	-	-
5240 & 5400	21½ (546)	22 (559)	22 (559)	22¾ (578)	25½ (648)	26¼ (667)	27¾ (705)	28¾ (730)	30¾

## COVER PLATES - DUPLEX UNITS INCHES (mm)

	A SUMP SIZE	B	E							K	
			5200		5240			5200			
			1½B	2D	2D	1½E	2-1/2E	3D	4D		4E
SQUARE	36 (914)	40 (1016)	2 (51)	2 (51)	†2¼ (57)	†2¼ (57)	†2¼ (70)	0 (0)	†1¼ (44)	†1¼ (44)	10
	42 (1067)	46 (1168)	6 (152)	6 (152)	1¾ (44)	1¾ (44)	1¼ (32)	4 (102)	2¾ (70)	2¾ (70)	10
	48 (1219)	54 (1372)	9 (229)	9 (229)	4¾ (121)	4¾ (121)	4¾ (108)	7 (178)	5¾ (146)	5¾ (146)	12
	54 (1372)	60 (1524)	10 (254)	10 (254)	5¾ (146)	5¾ (146)	5¾ (133)	8 (203)	6¾ (171)	6¾ (171)	14
	60 (1524)	66 (1676)	10 (254)	10 (254)	5¾ (146)	5¾ (146)	5¾ (133)	8 (203)	6¾ (171)	6¾ (171)	16
	72 (1829)	78 (1981)	12 (305)	12 (305)	7¾ (197)	7¾ (197)	7¾ (184)	10 (254)	8¾ (222)	8¾ (222)	18
	ROUND	36 (914)	40 (1016)	8 (203)	8 (203)	3¾ (95)	3¾ (95)	3¾ (83)	6 (152)	4¾ (121)	4¾ (121)
42 (1067)		46 (1168)	9 (229)	9 (229)	4¾ (121)	4¾ (121)	4¾ (108)	7 (178)	5¾ (146)	5¾ (146)	11
48 (1219)		54 (1372)	11 (279)	11 (279)	6¼ (171)	6¼ (171)	6¼ (159)	9 (229)	7¾ (197)	7¾ (197)	12
54 (1372)		60 (1524)	10 (254)	10 (254)	5¾ (146)	5¾ (146)	5¾ (133)	8 (203)	6¾ (171)	6¾ (171)	14
60 (1524)		66 (1676)	10 (254)	10 (254)	5¾ (146)	5¾ (146)	5¾ (133)	8 (203)	6¾ (171)	6¾ (171)	16
72 (1829)		78 (1981)	13 (330)	13 (330)	8¾ (222)	8¾ (222)	8¾ (210)	11 (279)	9¾ (248)	9¾ (248)	18

SUMP DEPTH IN FEET (M)	NO. OF INTERMEDIATE BEARINGS
0 to 3.5 (0 to 1.07)	(5200) 0
0 to 4.5 (0 to 1.4)	(5240+5400) 0
4 to 6 (1.2 to 1.9)	(5200) 1
5 to 8 (1.5 to 2.4)	(5240+5400) 1
6.5 to 8 (2 to 2.4)	(5200) 2
9 to 12 (2.7 to 3.7)	(5240+5400) 2 (5200) 3

## PUMP SIZE INCHES (mm)

PUMP SIZE	F	G	PUMP DISCHARGE
5200 1½B	6½ (165)	4½ (114)	Screwed 1½" NPT
5200 2D	7 (178)	5 (127)	Screwed 2" NPT
5240 2D	11¾ (283)	2¼ (57)	Screwed 2" NPT
5240 1½E	10¾ (260)	3 (76)	Screwed 1½" NPT
5240 2½E	11¾ (286)	3 (76)	Screwed 2½" NPT
5400 3D	9 (229)	4 (95)	Screwed 3" NPT
5400 4D	10¾ (276)	7¼ (184)	Flanged 4" 125#ASA
5400 4E	11¾ (302)	7¼ (184)	Flanged 4" 125#ASA

NOTE 1: High water alarm furnished only when specified.

NOTE 2: Sump depth determined by actual job requirements.

NOTE 3: Series 5200 and 5240 have Vertical Discharge. Series 5400 has 45° Elbow Discharge.

\*Dimensions F, G, & H apply to both Simplex and Duplex units.

† Denotes minus dimension as centerline of pump is left of cover plate center.

## Typical Specifications

Furnish and install, as illustrated on the plans & specifications, an Armstrong Series 5000 simplex or duplex pumping system.

### PUMPS - 5200

Sump Pump shall be Model: 5200 \_\_\_\_\_ vertical centrifugal, flexible coupled for sump service. Each pump shall provide \_\_\_\_\_ USgpm at \_\_\_\_\_ feet of TDH at a speed of \_\_\_\_\_ rpm. Pump length will be suitable for a pit depth of \_\_\_\_\_ feet.

The pump casing shall be cast iron with a bronze enclosed impeller complete with a cast iron inlet strainer.

Pump shaft shall be one piece 304 centerless ground stainless steel. Pump shaft shall be guided by grease lubricated upper ball bearing and intermediate bronze sleeve type column bearing(s). Pump column assembly is constructed of threaded steel schedule 80 pipe.

Intermediate bearing(s) are greased by a lubrication system consisting of ¼" (6.35mm) copper grease lines and Alemite fittings terminating at floor plate.

### PUMPS - 5240

Sump Pump shall be Model: 5240 \_\_\_\_\_ vertical centrifugal, flexible coupled for sump service. Each pump shall provide \_\_\_\_\_ USgpm at \_\_\_\_\_ feet of TDH at a speed of \_\_\_\_\_ rpm. Pump length will be suitable for a pit depth of \_\_\_\_\_ feet.

The pump casing shall be cast iron with a bronze enclosed impeller complete with a cast iron inlet strainer.

Pump shaft shall be one piece 1¼" (32 mm) diameter carbon steel or 304 turned and polished stainless steel. Pump Shaft shall be guided by grease lubricated upper ball bearing and intermediate bronze sleeve type column bearing(s). Flanged steel column assembly is complete with register fit guide bearing housings to ensure proper alignment.

The upper bearing(s) will be ball type, heavy duty grease lubricated, mounted in a raised bearing housing to prevent moisture, and dust and dirt contact. Intermediate and lower bearing(s) are greased by a lubrication system consisting of ¼" (6.35 mm) copper grease lines and Alemite fitting(s) terminating at floor plate.

### PUMPS - 5400

Sewage Pump shall be Model: 5400 \_\_\_\_\_ vertical centrifugal, flexible coupled for sewage service. Each pump shall provide \_\_\_\_\_ USgpm at \_\_\_\_\_ feet of TDH at a speed of \_\_\_\_\_ rpm. Pump length will be suitable for a pit depth of \_\_\_\_\_ feet. Pump shall be capable of passing solids sizes of 2" (51 mm) and 2½" (64 mm).

The pump casing shall be cast iron complete with a non-clog cast iron 2 vane open type impeller.

Pump shaft shall be one piece 1¼" (32 mm) diameter carbon steel or 304 turned and polished stainless steel. Pump shaft shall be guided by grease lubricated upper ball bearing(s) and intermediate bronze sleeve type column bearing(s). Flanged steel column assembly is complete with register fit guide bearing housings to ensure proper alignment. Packing seal provides "GAS TIGHT" construction.

The upper bearing(s) will be a ball type, heavy duty grease lubricated, mounted in a raised bearing housing to prevent moisture, and dust and dirt contact. Intermediate and lower bearing(s) are greased by a lubrication system consisting of ¼" (6.35 mm) copper grease lines and Alemite fitting(s) terminating at floor plate.

### MOTOR

Pump motor shall be a vertical type round body design. Motor horsepower shall be not less than \_\_\_\_\_ hp, \_\_\_\_\_ volts, \_\_\_\_\_ phase, 60 Hz. Motor

Enclosure shall be ODP, TEFC or Explosion Proof.

### OPTIONAL CONSTRUCTION: 5240 & 5400 PUMPS

**Cutless Rubber Lower & Intermediate Sleeve Bearings:** Cutless Rubber Lower & Intermediate Sleeve Bearings are provided to handle abrasive liquids without scoring or damaging the shaft. A separate fresh water line connection is provided for connection to outside source with solenoid valve (supplied by others) to be energized when pump motor operates. Pumps are complete with stainless steel shaft for longer bearing life.

**Graphite Lower & Intermediate Bearings:** Graphalloy intermediate and lower bearings are provided to handle liquids above 150°F (65°C). Pump is complete with stainless steel shaft for longer bearing life. For condensate applications, pump is complete with bronze impeller.

### PUMP CONTROL

Pump control shall be ball & rod mechanical float switch. Unit consists of copper ball, brass rod & stops. Float switch is mounted on a cast iron pedestal and bolted to sump cover plate.

Duplex unit with mechanical alternating float switch complete with high level emergency start position turning on both pumps in case of high liquid level.

### HIGH LEVEL ALARM

System shall include compression type high water alarm complete with alarm buzzer and additional contact for remote signaling. Alarm shall be housed in a NEMA 1 enclosure and mounted on sump cover plate.

### CONTROL PANEL

Armstrong series 5000 systems shall include NEMA 1 Control Panel with the following Standard Features:

- UL 508 or CSA approved
- Main Disconnect
- Thermal and Short Circuit Protection using Internal Circuit Breakers
- Failure Protection with Automatic Transfer to Non-Operating Pump (Duplex System)
- Control Transformer with Fused Primary (UL 508 only)
- Power-On and Pump-Run Indicating Light
- Hand-Off-Automatic Selector Switch

### OPTIONAL CONTROL FEATURES

- NEMA 2, 3, 4, 4X or 7 Enclosure
- High Level Buzzer or 4" (101 mm) Bell, Indicating Light and Silence Reset Push Button
- Overload Pilot Lights
- Elapsed Time Meters
- Individual Disconnect Switches

### COVER PLATE AND CURB FRAME

Circular or square sump cover plate and curb frame shall be supplied with openings for simplex and duplex pump configurations. Cover plate includes 3" (76 mm) NPT threaded vent and inspection cover.

**S. A. Armstrong Limited**  
23 Bertrand Avenue  
Toronto, Ontario  
Canada, M1L 2P3  
T: +1 416-755-2291  
F: +1 416-759-9101

**Armstrong Pumps Inc.**  
93 East Avenue  
North Tonawanda, New York  
U.S.A., 14120-6594  
T: +1 716-693-8813  
F: +1 716-693-8970

**Armstrong Integrated Limited**  
Wenlock Way  
Manchester  
United Kingdom, M12 5JL  
T: +44 (0) 8444 145 145  
F: +44 (0) 8444 145 146



© S. A. Armstrong Limited 2013