

## **KV Vertical Inline Pumps**

Taco Vertical Inline Pumps meet the latest standards for hydraulic performance and dimensional characteristics.



## Features & Benefits

### Quiet, dependable power. Proven performance.

Taco's extensive line of vertical inline pumps are designed for optimum performance and ease of installation. Doing your job once means doing it right... with pumps made by the world leader in hydronic technology for heating and cooling. Each pump we sell is backed by Taco's reputation for quality and dependability, and engineered for years of trouble-free service.

**Space Saving Design** Taco vertical inline pumps require no isolation pads. Their simplified in-the-line design saves you time and money.

**Back Pull-Out Design** Should a service call or maintenance ever be required, our pumps pull out from the back. There's no need to disconnect the pump from the piping system to work on it.

**Close Coupled Design** Each vertical inline pump features Taco's close coupled design for improved alignment and increased seal life. The bottom line? Fewer service calls.

**Lower Installed Cost** Because of the way we've engineered our pumps, they require less time to install, and require no special tools or hardware.

**Replaceable casing wear ring, pump support bracket** are all value added options.

**We've got you covered** With flows ranging up to 2500 GPM and heads up to 300' TDH, Taco can do the job

**Support Stand** These optional support stands, made of rugged ductile iron, can be added to all KV pump models. The already small footprint of KV pumps in tight mechanical rooms is further enhanced with the support stand's easy access bolt holes. Now installation and maintenance is that much easier.



- ① Standard NEMA JM Motor.
- ② Standard seal design allows for flexibility of seal options.
- ③ Pressure tapping on suction and discharge for easy verification of pump performance.

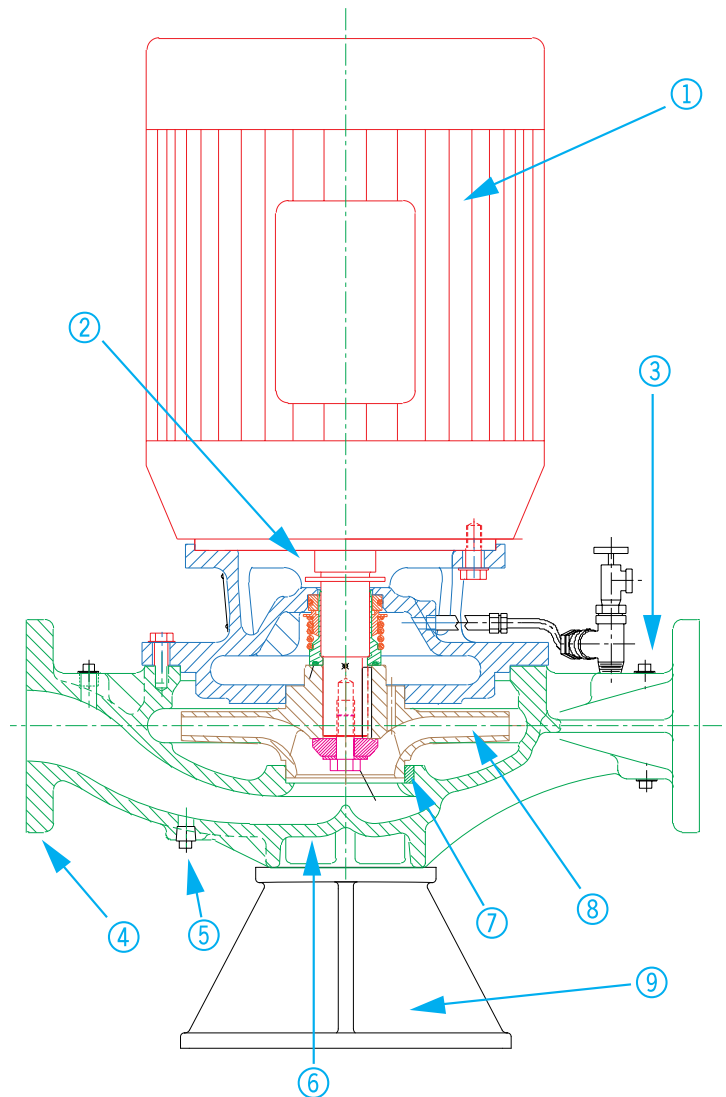

- ④ 250# flanges available
- ⑤ Casing drain
- ⑥ Machined mounting surface with tapped holes
- ⑦ Low cost replaceable optional wear ring available
- ⑧ High efficiency impellers standard on all models
- ⑨ Support Stand

# Commercial Hydronic Application Information

## Part I – Fundamentals

A centrifugal pump operated at constant speed delivers any capacity from zero to maximum depending on the head, design and suction conditions. Pump performance is most commonly shown by means of plotted curves which are graphical representations of a pump's performance characteristics. Pump curves present the average results obtained from testing several pumps of the same design under standardized test conditions. For a single family residential application, considerations other than flow and head are of relatively little economic or functional importance, since the total load is small and the equipment used is relatively standardized. For many smaller circulators, only the flow and pressure produced are represented on the performance curve (Fig. I-1).

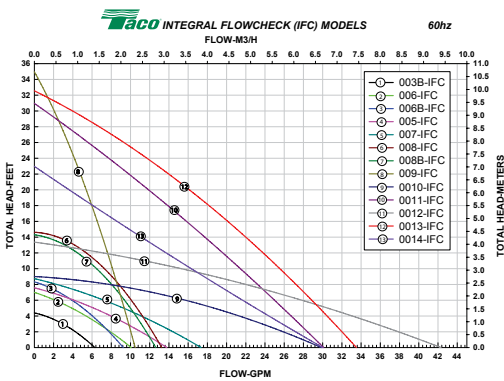

Fig. I-1

For larger and more complex buildings and systems, economic and functional considerations are more critical, and performance curves must relate the hydraulic efficiency, the power required, the shaft speed, and the net positive suction head required in addition to the flow and pressure produced (Fig. I-2).

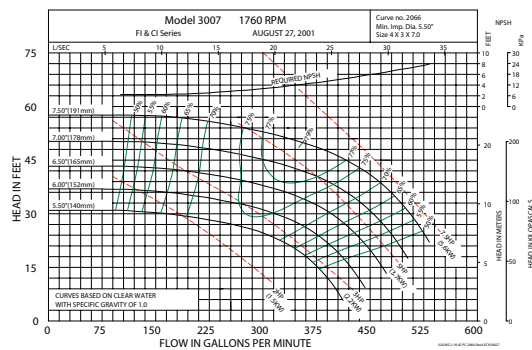

Fig. I-2

Pump performance curves show this interrelation of pump head, flow and efficiency for a specific impeller diameter and casing size. Since impellers of more than one diameter can usually be fitted in a given pump casing, pump curves show the performance of a given pump with impellers of various diameters. Often, a complete line of pumps of one design is available and a plot called a composite or quick selection curve can be used, to give a complete picture of the available head and flow for a given pump line (Fig. I-3).

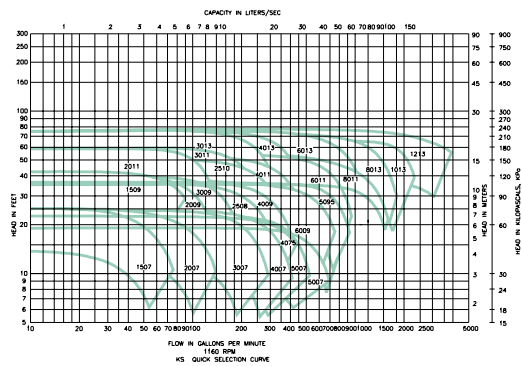

Fig. I-3

Such charts normally give flow, head and pump size only, and the specific performance curve must then be referred to for impeller diameter, efficiency, and other details. For most applications in our industry, pump curves are based on clear water with a specific gravity of 1.0.

## Part II – The System Curve

Understanding a system curve, sometimes called a system head curve, is important because conditions in larger, more complex piping systems vary as a result of either controllable or uncontrollable changes. A pump can operate at any point of rating on its performance curve, depending on the actual total head of a particular system. Partially closing a valve in the pump discharge or changing the size or length of pipes are changes in system conditions that will alter the shape of a system curve and, in turn, affect pump flow. Each pump model has a definite capacity curve for a given impeller diameter and speed. Developing a system curve provides the means to determine at what point on that curve a pump will operate when used in a particular piping system.

## Commercial Hydronic Application Information

Pipes, valves and fittings create resistance to flow or friction head. Developing the data to plot a system curve for a closed Hydronic system under pressure requires calculation of the total of these friction head losses. Friction tables are readily available that provide friction loss data for pipe, valves and fittings. These tables usually express the losses in terms of the equivalent length of straight pipe of the same size as the valve or fitting. Once the total system friction is determined, a plot can be made because this friction varies roughly as the square of the liquid flow in the system. This plot represents the SYSTEM CURVE. By laying the system curve over the pump performance curve, the pump flow can be determined (Fig. 2-1).

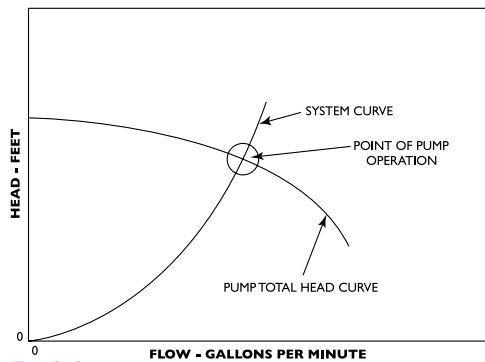

Fig. 2-1

Care must be taken that both pump head and friction are expressed in feet and that both are plotted on the same graph. The system curve will intersect the pump performance curve at the flow rate of the pump because this is the point at which the pump head is equal to the required system head for the same flow.

Fig. 2-2 illustrates the use of a discharge valve to change the system head to vary pump flow. Partially

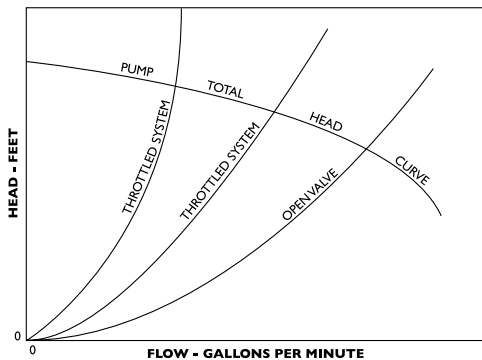

Fig. 2-2

closing the valve shifts the operating point to a higher head or lower flow capacity. Opening the valve has the opposite effect. Working the system curve against the pump performance curve for different total resistance possibilities provides the system designer important information with which to make pump and motor selection decisions for each system. A system curve is also an effective tool in analyzing system performance problems and choosing appropriate corrective action.

In an open Hydronic system, it may be necessary to add head to raise the liquid from a lower level to a higher level. Called static or elevation head, this amount is added to the friction head to determine the total system head curve. Fig. 2-3 illustrates a system curve developed by adding static head to the friction head resistance.

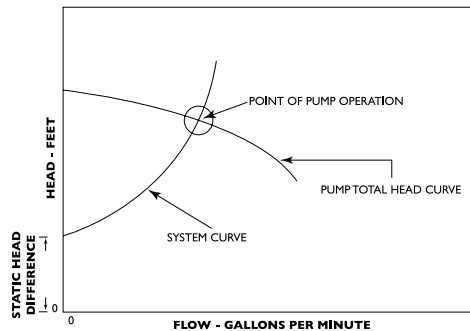

Fig. 2-3

### Part III - Stable Curves, Unstable Curves And Parallel Pumping

One of the ways in which the multitude of possible performance curve shapes of centrifugal pumps can be subdivided is as stable and unstable. The head of a stable curve is highest at zero flow (shutoff) and decreases as the flow increases. This is illustrated by the curve of Pump 2 in Fig. 3 - 1.

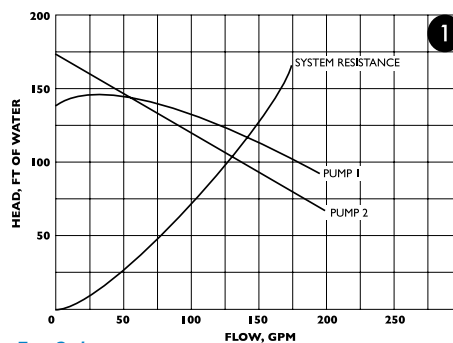

Fig. 3-1

## Commercial Hydronic Application Information

So-called unstable curves are those with maximum head not at zero, but at 5 to 25 percent of maximum flow, as shown by the curve for Pump 1 in Fig. 3 – 1.

The term unstable, though commonly used, is rather unfortunate terminology in that it suggests unstable pump performance. Neither term refers to operating characteristic, however. Each is strictly a designation for a particular shape of curve. Both stable and unstable curves have advantages and disadvantages in design and application. It is left to the discretion of the designer to determine the shape of his curve.

In a vast majority of installations, whether the pump curve is stable or unstable is relatively unimportant, as the following examples of typical applications show.

### Single Pump In Closed System

In a closed system, such as a Hydronic heating or cooling system, the function of the pump is to circulate the same quantity of fluid over and over again. Primary interest is in providing flow rate. No static head or lifting of fluid from one level to another takes place.

All system resistance curves originate at zero flow any head. Any pump, no matter how large or small, will produce some flow in a closed system.

For a given system resistance curve, the flow produced by any pump is determined by the intersection of the pump curve with the system resistance curve since only at this point is operating equilibrium possible. For each combination of system and pump, one and only one such intersection exists. Consequently, whether a pump curve is stable or unstable is of no consequence. This is illustrated in Fig. 3 – 1.

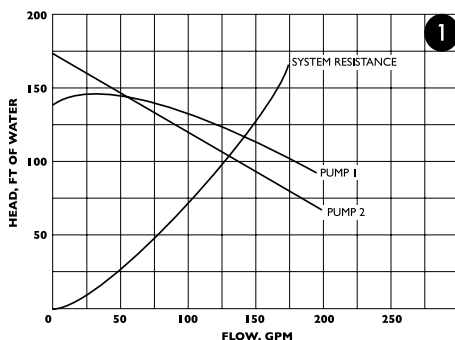

Fig. 3-1

### Single Pump In Open System With Static Head

In an open system with static head, the resistance curve originates at zero flow and at the static head to be overcome. The flow is again given by the intersection of system resistance and pump curves as illustrated for a stable curve in Fig. 3–2.

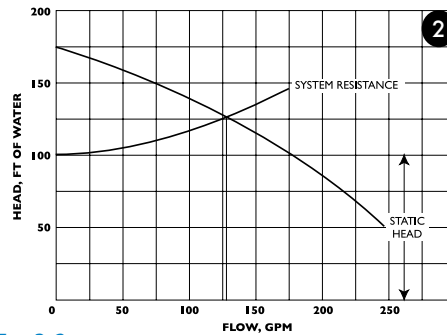

Fig. 3-2

It has been said that in an open system with static head a condition could exist where an unstable curve could cause the flow to “hunt” back and forth between two points since the system resistance curve intersects the pump curve twice, as shown in Fig. 3–3. The fallacy of this reasoning lies, in the fact that the pump used for the system in Fig. 3–3 already represents an improper selection in that it can never deliver any fluid at all. The shutoff head is lower than the static head. The explanation for this can be found in the manner in which a centrifugal pump develops its full pressure when the motor is started. The very important fact to remember here is that the shutoff head of the pump must theoretically always be at least equal to the static head.

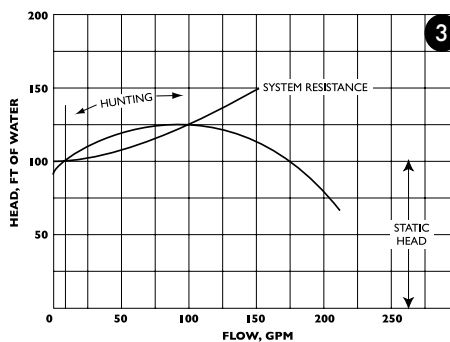

Fig. 3-3

## Commercial Hydronic Application Information

From a practical point of view, the shutoff head should be 5 to 10 percent higher than the static head because the slightest reduction in pump head (such as that caused by possible impeller erosion or lower than anticipated motor speed or voltage) would again cause shutoff head to be lower than static head. If the pump is properly selected, there will be only one resistance curve intersection with the pump curve and definite, unchanging flow will be established, as shown in Fig. 3-4.

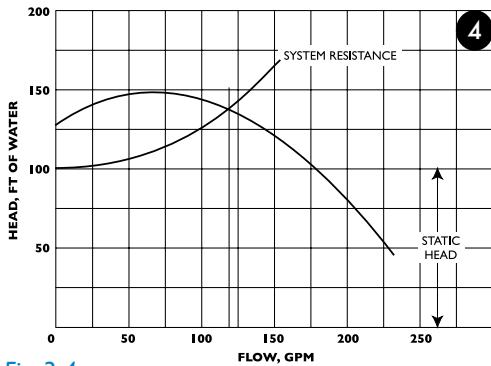

Fig. 3-4

### Pumps Operating In Parallel

In more complex piping systems, two or more pumps may be arranged for parallel or series operation to meet a wide range of demand in the most economical manner. When demand drops, one or more pumps can be shut down, allowing the remaining pumps to operate at peak efficiency. Pumps operating in Parallel give multiple flow capacity against a common head. When pumps operate in series, performance is determined by adding heads at the same flow capacity. Pumps to be arranged in series or parallel require the use of a system curve in conjunction with the composite pump performance curves to evaluate their performance under various conditions.

It is sometimes heard that for multiple pumping the individual pumps used must be stable performance curves. Correctly designed installations will give trouble-free service with either type of curve, however. The important thing to remember is that additional pumps can be started up only when their shutoff heads are higher than the head developed by the pumps already running.

If a system with fixed resistance (no throttling devices such as modulating valves) is designed so that its head, with all pumps operating (maximum flow) is less than the shutoff head of any individual pump, the different pumps may be operated singly or in any combination, and any starting sequence will work. Fig. 3-5 shows an example consisting of two dissimilar unstable pumps operating on an open system with static head.

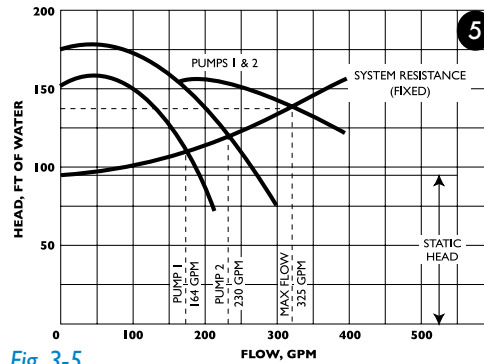

Fig. 3-5

It is also important to realize that stable curves do not guarantee successful parallel pumping by the mere fact that they are stable. Fig. 3-6 illustrates such a case. Two dissimilar pumps with stable curves are installed in a closed system with variable resistance (throttling may be affected by manually operated valves, for example).

With both pumps running, no benefit would be obtained from Pump 1 with the system resistance set to go through A, or any point between 0 and 100 GPM, for that matter. In fact, within that range, fluid from Pump 2 would flow backward through Pump 1 in spite of its running, because pressure available from Pump 2 would flow backward through Pump 1 in spite of its running, because pressure available from Pump 2 is greater than that developed by Pump 1. In other words, Pump 2 overpowers Pump 1.

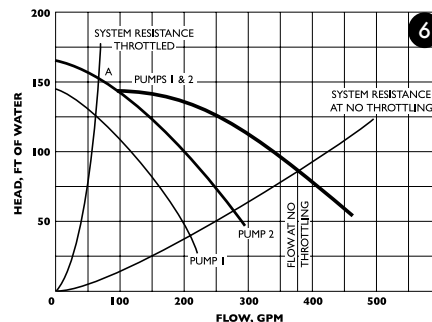

Fig. 3-6

## Commercial Hydronic Application Information

For this reason, with Pump 2 running alone, Pump 1 should not be started unless Pump 2 operates to the right of the point where the curve of Pump 2 and the curve of Pumps 1 and 2 diverge (100 GPM) in Fig.3–6.

Parallel pumping is often an excellent way to obtain optimum operating conditions and to save energy. To be successful, however, systems and operating conditions must be understood. This applies to both stable and unstable pump curves.

### Part IV – NPSH And Pump Cavitation

The net positive suction head (NPSH) is an expression of the minimum suction conditions required to prevent cavitation in a pump. NPSH can be thought of as the head corresponding to the difference between the actual absolute pressure at the inlet to the pump impeller and the fluid vapor pressure. An incorrect determination of NPSH can lead to reduced pump capacity and efficiency, severe operating problems and cavitation damage.

It is helpful to define separately two basic NPSH considerations; required NPSH (NPSHR) and available (NPSHA).

The required or minimum NPSH is dependent on the design of a particular pump and is determined by the manufacturer’s testing of each pump model. The pump manufacturer can plot this required NPSH for a given pump model on performance curve and this value, expressed as feet of the liquid handled, is the pressure required to force a given flow through the suction piping into the impeller eye of the pump. Required NPSH can also be defined as the amount of pressure in excess of the vapor pressure required by a particular pump model to prevent the formation of vapor pockets or cavitation. Required NPSH, then, varies from one pump manufacturer to the next and from one manufacturer’s model to another. The required NPSH for a particular pump model varies with capacity and rapidly increases in high capacities. The available NPSH, on the other hand, is dependent on the piping system design as well as the actual location of the pump in that system. The NPSH available as a function of system piping design must always be greater than the NPSH required by the pump in that system. The NPSH available as a function of system

piping design must always be greater than the NPSH required by the pump in that system or noise and cavitation will result. The available NPSH can be altered to satisfy the NPSH required by the pump, if changes in the piping liquid supply level, etc., can be made. Increasing the available NPSH provides a safety margin against the potential for cavitation. The available NPSH is calculated by using the formula:

$$NPSHA = ha +/- hs - hvpa - hf$$

where:

- ha** = atmospheric pressure in feet absolute
- hs “+”** = suction head or positive pressure in a closed system, expressed in feet gauge
- hs “-”** = suction lift or negative pressure in a closed system, expressed in feet gauge
- h<sub>vpa</sub>** = vapor pressure of the fluid in feet absolute
- hf** = pipe friction in feet between pump suction and suction reference point.

Cavitation can be defined as the formation and subsequent collapse of vapor pockets in a liquid. Cavitation in a centrifugal pump begins to occur when the suction head is insufficient to maintain pressures above the vapor pressure. As the inlet pressure approaches the flash point, vapor pockets form bubbles on the underside of the impeller vane which collapse as they move into the high-pressure area along the outer edge of the impeller. Severe cavitation can cause pitting of the impeller surface and noise levels audible outside the pump. The Taco pump performance curve below (Fig. 4–1) includes a plot of the required NPSH for a Taco Model 1506. If a pump capacity of 105 GPM is used as an example capacity requirement, reading vertically from that GPM rate shows a required NPSH of 4 feet. An available system NPSH greater than 4 feet would, therefore, be necessary to ensure satisfactory pump performance and operation.

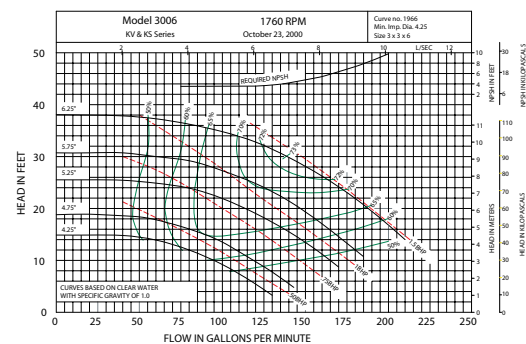
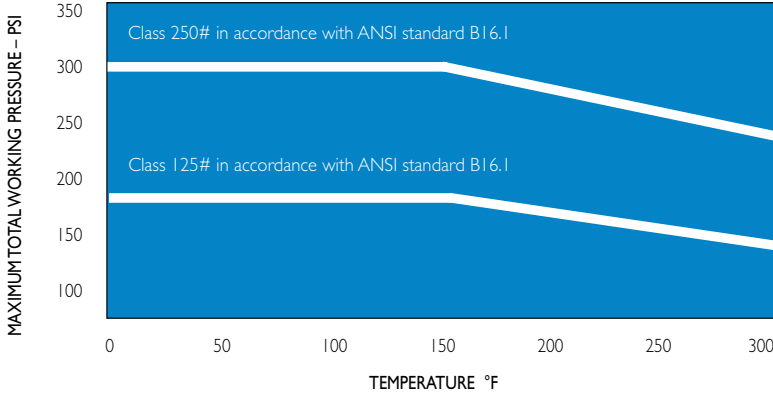

Fig. 4-1

# Commercial Hydronic Application Information

## Pressure-Temperature Ratings



OPERATING SPECIFICATIONS		
	Standard	Optional
Flange	ANSI Class 125*	ANSI Class 250*
Pressure	175 PSIG* 1210 KPA	300 PSIG* 2070 KPA
Temperature	250°F 120°C**	250°F 102°C**

ADDITIONAL OPTIONS	
Filters	Cuno 5 Micron
Separators	Kynar Cyclone Separator

\* Per Pressure Temperature Ratings chart above.

## Typical Specification

Furnish and install centrifugal in-line single stage pump(s) with capacities and characteristics as shown on the plans. The design must permit easy replacement of the mechanical shaft seal without removal of the motor. Pumps shall be Taco Model KV or approved equal.

Pump volute or casings shall be constructed of class 30 cast iron. The pump casing shall have equal suction and discharge ports. The pump casing shall be drilled and tapped for gauge ports at both the suction and discharge flanges and for drain port at the bottom of the casing. Optional bronze wear ring can be fitted to the casing. The pump shall be capable of being serviced without disturbing system piping.

The impeller shall be bronze and hydraulically balanced by either back vanes or balancing holes. The impeller shall be dynamically balanced to ANSI Grade G6.3 and shall be fitted to the shaft with a key.

The pump cover shall be machined to provide a balance chamber from the close tolerance between the back impeller hub and the cover. The cover shall be fitted with a bronze throttle bushing as standard. The

cover shall be designed to provide maximum flexibility of mechanical shaft seals and flush glands.

The pump seal shall be EPT Ceramic rated to 250 degrees F\*\*. Optional seat materials and elastomers are available. The pump shall have a factory installed vent/flush line to insure removal of trapped air and mechanical seal cooling. The vent/flush line shall run from the seal chamber to the pump discharge. Extended seal life can be accomplished with an optional filter or sediment separator, which can be incorporated in the vent/flush line.

The pump shall be coupled to a NEMA rated motor designed for continuous operation and readily removable for servicing. The pump shaft shall be of stainless steel and incorporate a suitable internal or external seal. The pump and motor shaft must be connected with circular keys capable of transmitting axial loads to the motor bearings. The motor shall be connected to the pump shaft through a high tensile aluminum split style coupling.

\*\* For operating temperatures above 250°F, a cooled flush is required and is recommended for temperatures above 225°F for optimum seal life. On closed systems, insert a small heat exchanger in the flush line to cool the seal flushing fluid.

# Commercial Hydronic Application Information

## KV Vertical Inline Pump Materials of Construction

Description	Bronze Fitted		All Iron	
	Standard	Optional	Standard	Optional
Casing	Cast Iron ASTM A48 Class 30A	N/A	Cast Iron ASTM A48 Class 30A	N/A
Impeller	Bronze ASTM B584-836	CF	Cast Iron ASTM A48 Class 30A	CF
Wear Ring	None	Bronze ASTM B584-932 SAE660	None	N/A
Shaft	Carbon Steel	Stainless Steel AISI 416 ASTM A582	Carbon Steel	Stainless Steel AISI 416 ASTM A582
Shaft Sleeve	Bronze ASTM B584-932 SAE660	Stainless Steel AISI 303 ASTM A276	Stainless Steel AISI 303 ASTM A276	CF
Mechanical Seal	Ceramic / EPT	Tungston Carbide / EPT	Ceramic / EPT	Tungston Carbide / EPT
Mechanical Seal Flush Line	Copper	CF	Stainless Steel	CF
Support Stand	N/A	Ductile Iron ASTM A536-84 Grade 65-45-12	N/A	Ductile Iron ASTM A536-84 Grade 65-45-12

CF - Consult Factory

N/A - Not Available

## KV Series Performance Field 1160 RPM

Curves also available on TacoNet®

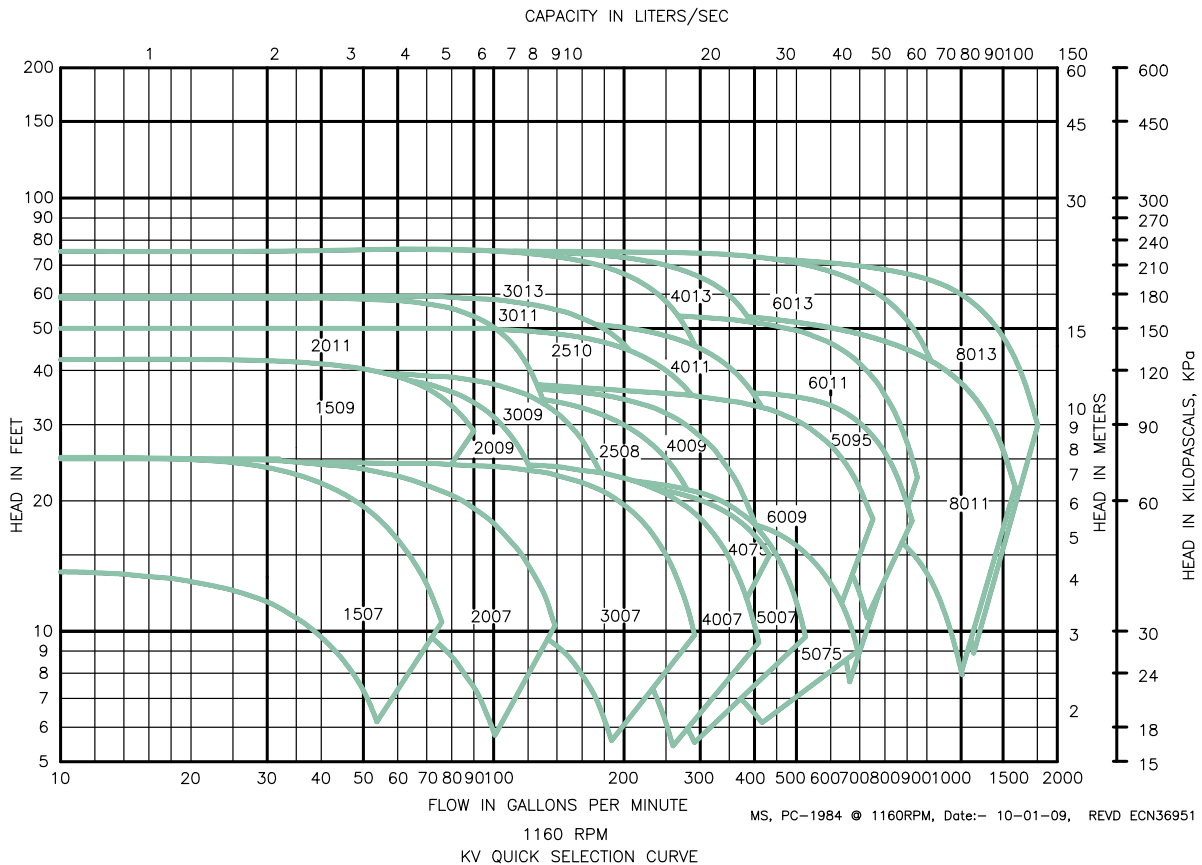

# Commercial Hydronic Application Information

## KV Series Performance Field 1450 RPM Curves also available on TacoNet®

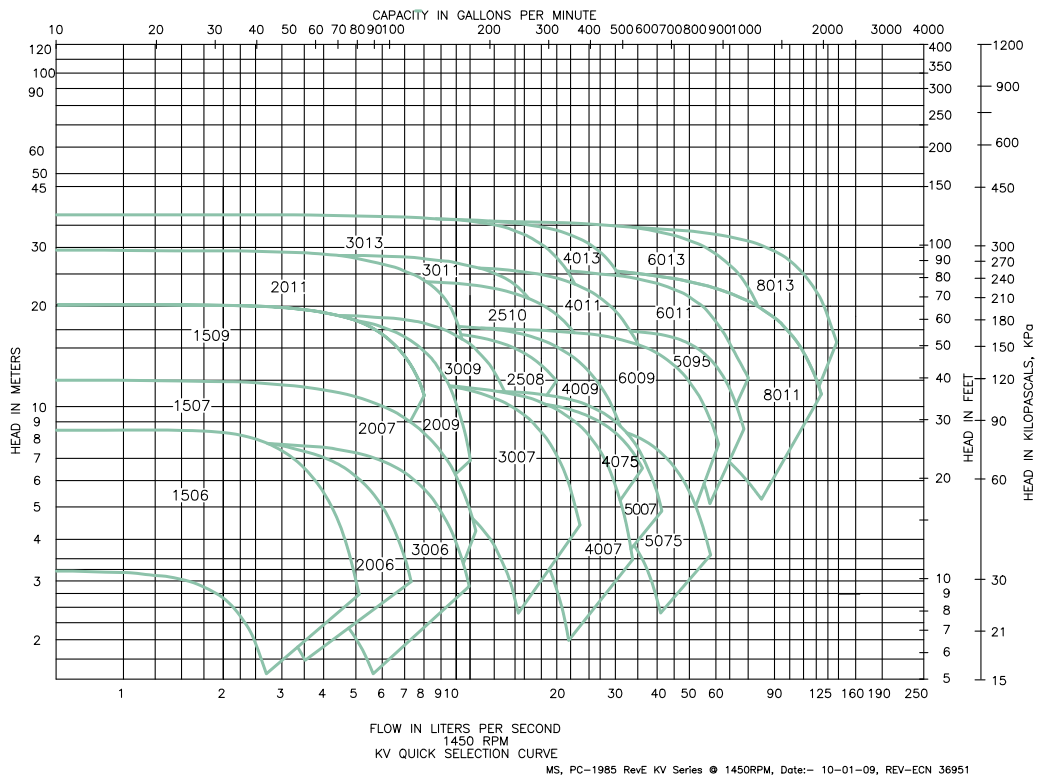

## KV Series Performance Field 1760 RPM Curves also available on TacoNet®

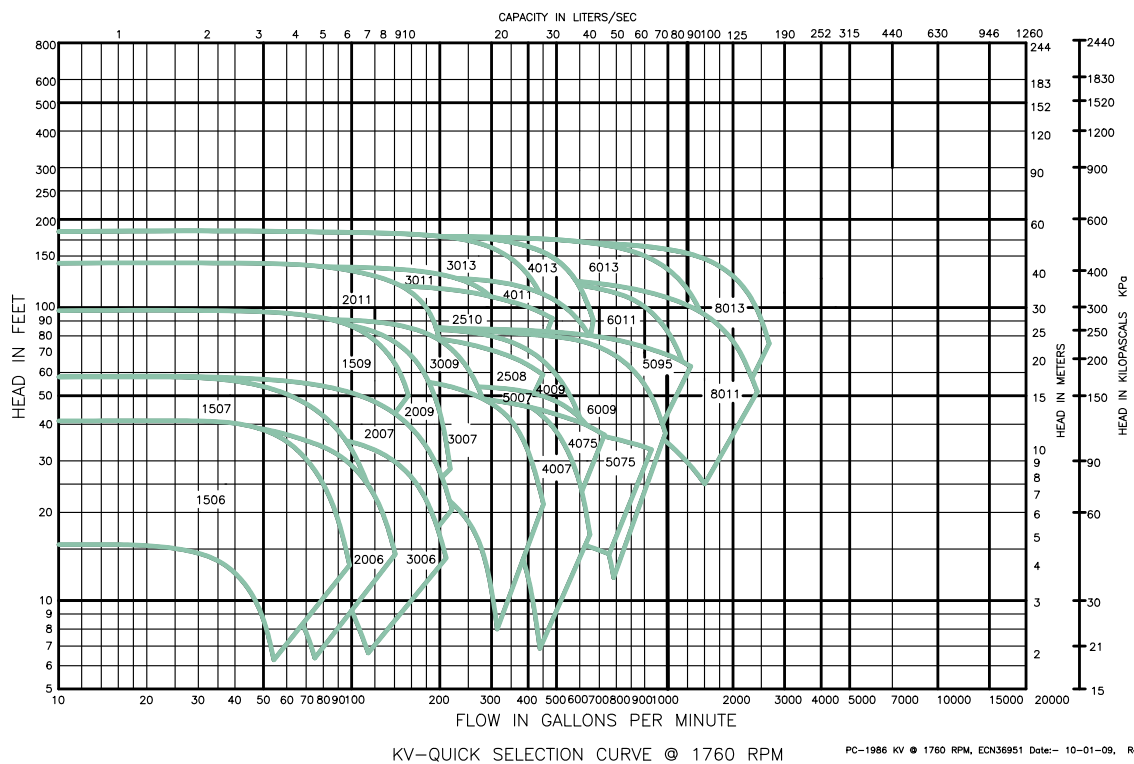

# Commercial Hydronic Application Information

## KV Series Performance Field 2900 RPM

Curves also available on TacoNet®

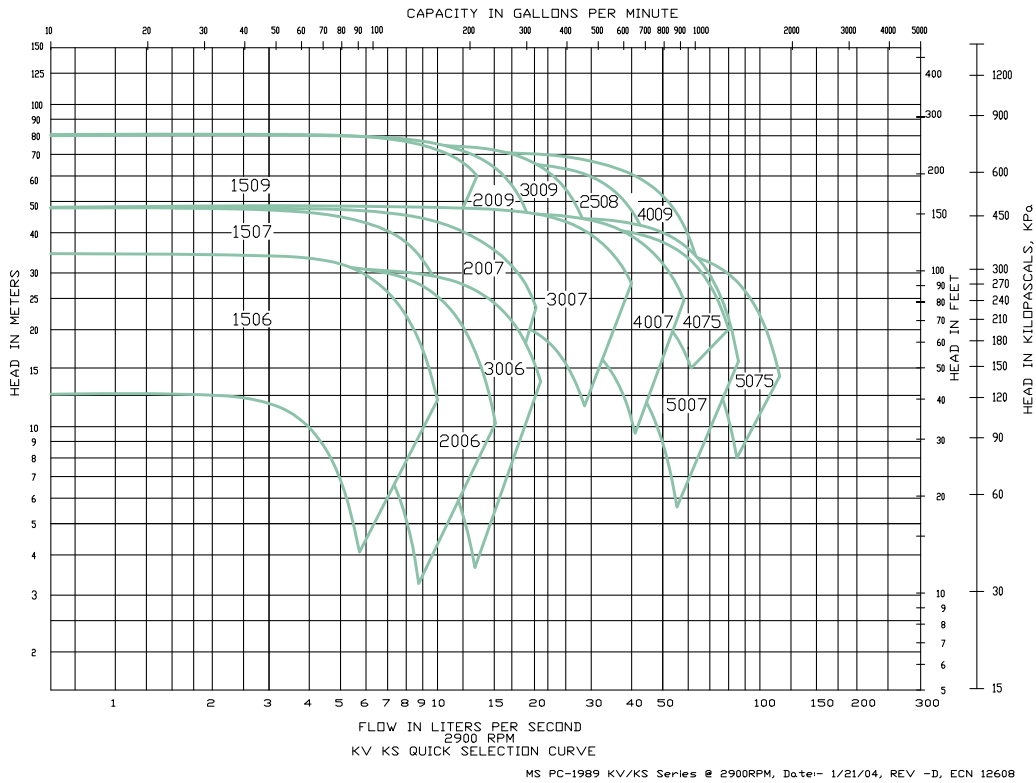

## KV Series Performance Field 3500 RPM

Curves also available on TacoNet®

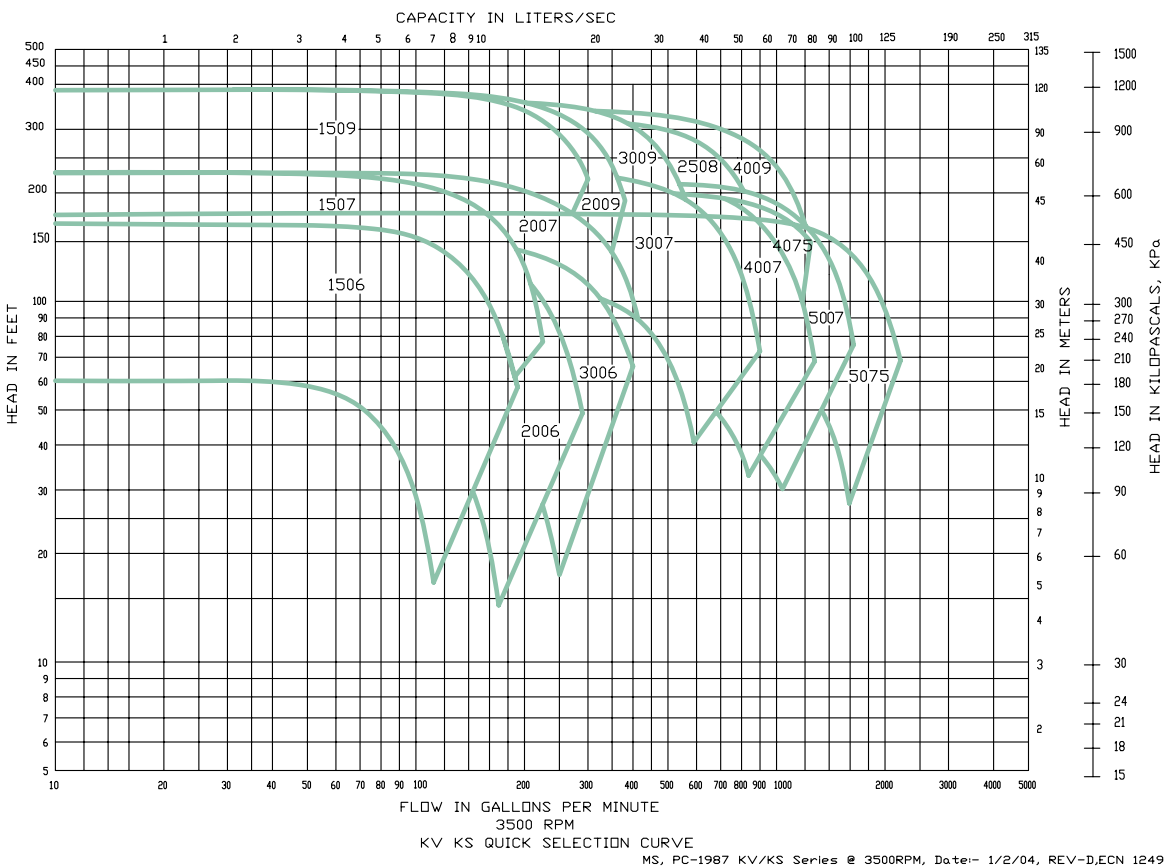

## KV Vertical Pump Support Stand Dimensions

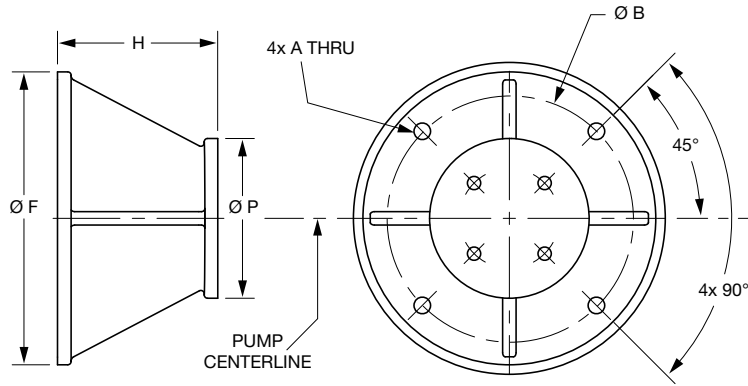

PUMPS USED ON	A	ØB	ØF	H	ØP	SUPPORT STAND WEIGHT
KV/KS1506	6.00	0.63	7.50	6.00	3.25	10 LBS
KV/KS1507						
KV/KS1509						
KV/KS2007	7.75	0.63	9.38	6	4.88	19 LBS
KV/KS3007						
KV/KS4007						
KV/KS2006						
KV/KS2009						
KV/KS2011	9.25	0.63	11	6	6	26 LBS
KV/KS2508						
KV/KS2510						
KV/KS3006						
KV/KS3009						
KV/KS3011	10.63	0.75	12.63	6.5	7.63	47 LBS
KV/KS4075						
KV/KS3013						
KV/KS4009						
KV/KS4011	11.88	0.75	14.38	6.75	9.38	66 LBS
KV/KS4013						
KS/KS5007						
KV/KS5075						
KV/KS5095						
KV/KS6009	14.5	0.75	16.5	7.2	11.5	100 LBS
KV/KS6095						
KV/KS6011						
KV/KS6013						
KS1013	24.00	1.13	28.00	8.00	24.00	343 LBS
KS1016						
KS8016	24	1.13	28	8	21	311 LBS
KV/KS8011						
KV/KS8013						
KS1217						
KS1415						
KS1213						

# KV Vertical Inline Pump Dimensions

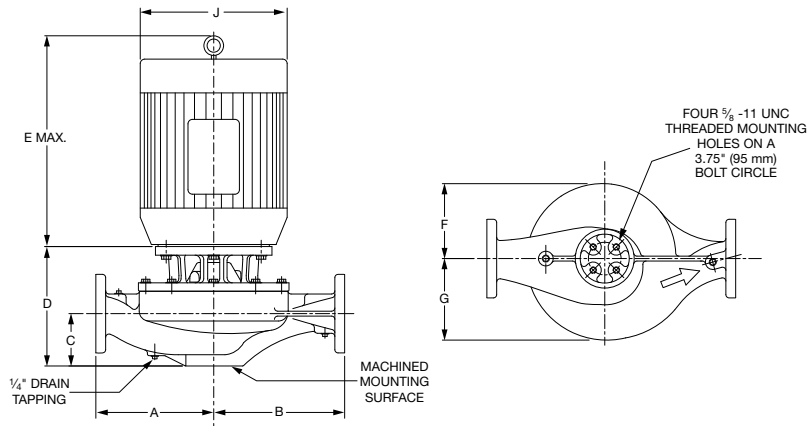

MODEL NO. "KV"	PRESSURE CLASS-125#		PRESSURE CLASS-250#		C	D	F	G	E MAX.	J DIA	MOTOR FRAME SIZE					
	A															
1 1/2 X 1 1/2 X 6 (KV1506)	7.50(191MM)	7.50(191MM)	7.75(197MM)	7.75(197MM)	4.49(114MM)	8.65(220MM)	4.13(105MM)	4.63(118MM)	12.06(306MM)	6.62(168MM)	143					
									13.43(341MM)			7.88(200M)	145			
									13.94(354MM)					182		
									15.58(396MM)						184	
2 X 2 X 6 (KV2006)	7.50(191MM)	8.00(203MM)	7.75(197MM)	8.25(210MM)	3.91(99MM)	8.11(206MM)	4.41(112MM)	5.14(131MM)	12.06(306MM)	6.62(168MM)	143					
									13.43(341MM)			7.88(200M)	145			
									13.94(354MM)					182		
									15.58(396MM)						184	
									16.68(424MM)							213
3 X 3 X 6 (KV3006)	8.50(216MM)	10.00(254MM)	8.87(225MM)	10.37(263MM)	4.97(126MM)	9.13(232MM)	4.67(119MM)	5.56(141MM)	12.06(306MM)	6.62(168MM)	143					
									13.43(341MM)			7.88(200M)	145			
									13.94(354MM)					182		
									15.58(396MM)						184	
									16.68(424MM)							213
1 1/2 X 1 1/2 X 7 (KV1507)	8.00(203MM)	8.00(203MM)	8.31(211MM)	8.31(211MM)	4.13(105MM)	8.42(214MM)	4.88(124MM)	5.16(131MM)	12.06(306MM)	6.62(168MM)	143					
									13.43(341MM)			7.88(200M)	145			
									13.94(354MM)					182		
									15.58(396MM)						184	
									16.68(424MM)							213
2 X 2 X 7 (KV2007)	8.50(216MM)	8.50(216MM)	8.76(223MM)	8.76(223MM)	3.94(100MM)	8.27(210MM)	4.88(124MM)	5.45(138MM)	12.06(306MM)	6.62(168MM)	143					
									13.43(341MM)			7.88(200M)	145			
									13.94(354MM)					182		
									15.58(396MM)						184	
									16.68(424MM)							213
3 X 3 X 7 (KV3007)	10.00(254MM)	10.00(254MM)	10.37(263MM)	10.37(263MM)	6.30(160MM)	10.53(267MM)	5.29(134MM)	6.31(160MM)	12.06(306MM)	6.62(168MM)	143					
									13.43(341MM)			7.88(200M)	145			
									13.94(354MM)					182		
									15.58(396MM)						184	
									16.68(424MM)							213
4 X 4 X 7 (KV4075)	11.81(300MM)	10.81(274MM)	12.12(307MM)	11.12(282MM)	6.94(176MM)	11.96(303MM)	5.61(142MM)	6.99(177MM)	13.43(341MM)	6.62(168MM)	145					
									13.94(354MM)			7.88(200M)	182			
									15.58(396MM)					184		
									16.68(424MM)						213	
									23.39(594MM)							286
4 X 4 X 7 (KV4007)	11.00(279MM)	11.00(279MM)	11.32(288MM)	11.32(288MM)	6.59(167MM)	11.21(285MM)	5.64(143MM)	6.80(173MM)	12.06(306MM)	6.62(168MM)	143					
									13.43(341MM)			7.88(200M)	145			
									13.94(354MM)					182		
									15.58(396MM)						184	
									16.68(424MM)							213
5 X 5 X 7 (KV5007)	13.00(330MM)	11.00(279MM)	13.44(341MM)	11.44(291MM)	6.63(168MM)	11.58(294MM)	6.42(163MM)	7.91(201MM)	13.43(341MM)	6.62(168MM)	145					
									13.94(354MM)			7.88(200M)	182			
									15.58(396MM)					184		
									16.68(424MM)						213	
									18.18(462MM)							256
									19.91(506MM)	12.94(329MM)	284					
									23.39(594MM)			15.29(388MM)	286			
									25.28(642MM)					17.85(453MM)	324	
																286
									13.43(341MM)	6.62(168MM)	145					
									13.94(354MM)			7.88(200M)	182			
									15.58(396MM)					184		
									16.68(424MM)						213	
									18.18(462MM)							256
									19.91(506MM)	12.94(329MM)	284					
									23.39(594MM)			15.29(388MM)	286			
									25.28(642MM)					17.85(453MM)	324	
																286

## KV Vertical Inline Pump Dimensions, continued

MODEL NO. "KV"	PRESSURE CLASS-125#		PRESSURE CLASS-250#		C	D	F	G	E MAX.	J DIA	MOTOR FRAME SIZE
	A	B	A	B							
5X5X7 (KV5075)	14.00(355MM)	11.00(279MM)	14.44(366MM)	11.44(291MM)	8.07(205MM)	13.22(335MM)	6.31(160MM)	8.10(205MM)	13.43(341MM)	6.62(168MM)	145
									13.94(354MM)	7.88(200MM)	182
									15.58(396MM)		184
									16.68(424MM)	9.56(234MM)	213
									18.18(462MM)		215
									23.39(594MM)	15.29(388MM)	284
25.28(642MM)	17.85(453MM)	286									
						14.31(363MM)					324
											326
2 1/2X 2 1/2X8 (KV 2508)	9.56(242MM)	9.00(228MM)	9.88(250MM)	9.31(236MM)	5.88(149MM)	10.27(260MM)	6.10(155MM)	6.99(177MM)	13.43(341MM)	6.62(168MM)	145
						13.94(354MM)			7.88(200MM)	182	
						15.58(396MM)				184	
						16.68(424MM)			9.56(234MM)	213	
						18.18(462MM)				215	
						23.39(594MM)			15.29(388MM)	284	
25.28(642MM)	17.85(453MM)	286									
						10.27(260MM)					324
						10.89(276MM)					326
1 1/2X1 1/2X9 (KV1509)	8.00(203MM)	8.00(203MM)	8.31(211MM)	8.31(211MM)	4.36(111MM)	9.19(233MM)	5.72(145MM)	6.22(158MM)	12.06(306MM)	6.62(168MM)	143
						13.43(341MM)				145	
						13.94(354MM)			7.88(200MM)	182	
						15.58(396MM)				184	
						18.18(462MM)			9.56(234MM)	215	
						17.83(453MM)			12.94(329MM)	254	
19.91(506MM)		256									
						9.19(233MM)					284
											286
2X2X9 (KV2009)	9.00(229MM)	10.00(254MM)	9.25(235MM)	10.25(260MM)	3.94(100MM)	8.29(211MM)	5.72(145MM)	6.22(158MM)	12.06(306MM)	6.62(168MM)	143
						13.43(341MM)				145	
						13.94(354MM)			7.88(200MM)	182	
						15.58(396MM)				184	
						16.68(424MM)			9.56(234MM)	213	
						18.18(462MM)				215	
17.83(453MM)	12.94(329MM)	254									
19.91(506MM)		256									
						8.29(211MM)					284
						8.90(226MM)					286
3X3X9 (KV3009)	10.00(254MM)	11.00(279MM)	10.37(263MM)	11.37(289MM)	5.19(132MM)	9.47(241MM)	5.94(151MM)	6.53(166MM)	12.06(306MM)	6.62(168MM)	143
						13.43(341MM)				145	
						13.94(354MM)			7.88(200MM)	182	
						15.58(396MM)				184	
						16.68(424MM)			9.56(234MM)	213	
						17.83(453MM)			12.94(329MM)	254	
19.91(506MM)		256									
						9.47(241MM)					284
						9.99(253MM)					286
											324
4X4X9 (KV4009)	11.00(279MM)	13.00(330MM)	11.32(288MM)	13.32(338MM)	6.19(157MM)	10.58(269MM)	6.28(160MM)	7.25(184MM)	13.43(341MM)	6.62(168MM)	145
						13.94(354MM)				182	
						15.58(396MM)			7.88(200MM)	184	
						16.68(424MM)			9.56(234MM)	213	
						18.18(462MM)				215	
						17.83(453MM)			12.94(329MM)	256	
23.39(594MM)	15.29(388MM)	284									
25.28(642MM)	17.85(453MM)	286									
						10.58(269MM)					324
						11.20(284MM)					326
5X5X9 (KV5095)	14.00(355MM)	11.00(279MM)	14.44(366MM)	11.44(290MM)	7.34(186MM)	12.25(311MM)	7.37(187MM)	9.08(230MM)	15.58(396MM)	7.88(200MM)	184
						16.68(424MM)			9.56(234MM)	213	
						18.18(462MM)				215	
						17.83(453MM)			12.94(329MM)	254	
						19.91(506MM)				256	
						23.39(594MM)			15.29(388MM)	284	
						12.25(311MM)					284
						12.87(326MM)					

# KV Vertical Inline Pump Dimensions, continued

MODEL NO. "KV"	PRESSURE CLASS-125#		PRESSURE CLASS-250#		C	D	F	G	E MAX.	J DIA	MOTOR FRAME SIZE	
	A	B	A	B								
6X6X9 (KV6009)	13.50(343MM)	15.50(394MM)	13.82(351MM)	15.82(402MM)	6.60(168MM)	11.44(291MM)	7.62(194MM)	9.31(236MM)	15.58(396MM)	7.88(200M)	184	
									16.68(424MM)	9.56(234MM)	213	
									18.18(462MM)		215	
									17.83(453MM)		254	
									19.91(506MM)	12.94(329MM)	256	
23.39(594MM)	15.29(388MM)	284										
2-1/2X2-1/2X10 (KV2510)	11.25(285MM)	9.75(247MM)	11.56(293MM)	10.06(255MM)	6.79(172MM)	11.30(287MM)	7.06(179MM)	7.71(195MM)	15.58(396MM)	7.88(200M)	184	
						11.30(287MM)			9.56(234MM)	213		
						11.97(304MM)				215		
						17.83(453MM)			12.94(329MM)	254		
19.91(506MM)	15.29(388MM)	256										
2X2X11 (KV2011)	10.50(267MM)	10.85(276MM)	10.75(273MM)	11.10(282MM)	3.94(100MM)	8.23(209MM)	7.06(179MM)	7.12(181MM)	13.43(341MM)	6.62(168MM)	145	
						13.94(354MM)			7.88(200M)	182		
						15.58(396MM)				184		
						16.68(424MM)				213		
						18.18(462MM)			9.56(234MM)	215		
8.23(209MM)	15.29(388MM)	254										
3X3X11 (KV3011)	11.50(292MM)	13.00(330MM)	11.88(302MM)	13.38(340MM)	6.00(152MM)	10.32(262MM)	7.10(180MM)	7.89(200MM)	13.43(341MM)	6.62(168MM)	145	
						13.94(354MM)			7.88(200M)	182		
						15.58(396MM)				184		
						16.68(424MM)				213		
						18.18(462MM)			9.56(234MM)	215		
11.08(281MM)	12.94(329MM)	254										
4X4X11 (KV4011)	13.50(343MM)	15.00(381MM)	13.81(351MM)	15.31(389MM)	6.29(160MM)	10.89(277MM)	7.74(197MM)	8.82(224MM)	15.58(396MM)	7.88(200M)	184	
						10.89(277MM)			9.56(234MM)	213		
						11.57(293MM)				215		
						17.83(453MM)				12.94(329MM)	254	
						19.91(506MM)			15.29(388MM)	256		
6X6X11 (KV6011)	16.00(406MM)	17.50(445MM)	16.32(415MM)	17.82(453MM)	7.82(199MM)	12.68(322MM)	8.61(219MM)	10.25(260MM)	16.68(424MM)	9.56(234MM)	213	
						13.33(338MM)			18.18(462MM)	12.94(329MM)	215	
									17.83(453MM)		254	
									19.91(506MM)	15.29(388MM)	256	
						23.39(594MM)			15.29(388MM)	284		
						25.28(642MM)			17.85(453MM)	286		
						8X8X11 (KV8011)			20.00(508MM)	19.50(495MM)	20.50(521MM)	20.00(508MM)
25.28(642MM)	17.83(453MM)	12.94(329MM)	254									
	19.91(506MM)		256									
	23.39(594MM)	15.29(388MM)	284									
25.28(642MM)	17.85(453MM)	324										
3X3X13 (KV3013)	13.63(346MM)	14.13(359MM)	14.00(356MM)	14.50(368MM)	5.93(151MM)	10.55(268MM)	8.31(211MM)	8.77(223MM)	15.58(396MM)	7.88(200M)	184	
						10.55(268MM)			9.56(234MM)	213		
						11.17(283MM)				215		
						17.83(453MM)				12.94(329MM)	254	
						19.91(506MM)			15.29(388MM)	256		
23.39(594MM)	15.29(388MM)	284										
4X4X13 (KV4013)	15.50(394MM)	15.50(394MM)	15.81(402MM)	15.81(402)	6.23(158MM)	10.89(277MM)	8.53(217MM)	9.52(242MM)	15.58(396MM)	7.88(200M)	184	
						10.89(277MM)			9.56(234MM)	213		
						11.51(292MM)				18.18(462MM)	215	
										17.83(453MM)	12.94(329MM)	254
						19.91(506MM)			15.29(388MM)	256		
23.39(594MM)	15.29(388MM)	284										
6X6X13 (KV6013)	17.00(432MM)	17.00(432MM)	17.32(440MM)	17.32(440MM)	8.17(208MM)	13.17(334MM)	13.79(350MM)	9.30(236MM)	11.48(292MM)	18.18(462MM)	9.56(234MM)	215
						13.79(350MM)			17.83(453MM)	12.94(329MM)	254	
									19.91(506MM)		256	
									23.39(594MM)	15.29(388MM)	284	
						25.28(642MM)			17.85(453MM)	324		
						27.21(691MM)			19.25(489MM)	364		
						8X8X13 (KV8013)			20.00(508MM)	21.00(533MM)	20.50(521MM)	21.50(546MM)
15.10(383MM)	23.39(594MM)	15.29(388MM)	284									
	25.28(642MM)		17.85(453MM)	286								
	27.21(691MM)	19.25(489MM)	324									
27.21(691MM)	19.25(489MM)	364										

# Taco quality through & through



Hydronic professionals everywhere trust Taco for the highest quality systems, components, technology, and support. Visit **taco-hvac.com** for more information on KV Vertical Inline Pumps, additional products, systems, software & training.



Taco Inc., 1160 Cranston Street, Cranston, RI 02920 / (401) 942-8000 / Fax (401) 942-2360  
Taco (Canada) Ltd., 8450 Lawson Road, Unit #3, Milton, Ontario L9T 0J8 / (905) 564-9422 / Fax (905) 564-9436  
[www.taco-hvac.com](http://www.taco-hvac.com)